

STANDARD MODELS OF *TECO* TUBE EXPANDERS



CH-900

For Condensers And Heat Exchangers.

Model: CH-900 Tube range: 1/4" to 3/8" O.D.
(6.35 to 9.52 mm) O.D.

Expander with 3/4" (19.05 mm) long rolls suitable for tube sheet thicknesses from 1/8" to 3/4" (3.175 mm to 19.05 mm).

Expander with 1 1/4" (31.75 mm) long rolls suitable for tube sheet thicknesses from 1/2" to 1 1/4" (12.70 mm to 31.75 mm).

CH-1300

Model: CH-1300 Tube range: 3/8" (9.52 mm) O.D.

Expander with 3/4" (19.05 mm) long rolls suitable for tube sheet thicknesses from 1/4" to 3" (6.35 mm to 76.20 mm).

Expander with 1 1/4" (31.75 mm) long rolls suitable for tube sheet thicknesses from 3/4" to 3 1/2" (19.05 mm to 88.90 mm).

CH-800

Model: CH-800 Tube range: 1/2" to 1 3/4" O.D.
(12.70 to 44.45 mm) O.D.

Expander with 1 1/2" (38.10 mm) long rolls suitable for tube sheet thicknesses from 1/4" to 1 1/2" (6.35 mm to 38.10 mm).

Expander with 2 1/4" (57.15 mm) long rolls suitable for tube sheet thicknesses from 1" to 2 1/4" (25.40 mm to 57.15 mm).

Special 4 or 5 roll models available.

CH-1200

Model: CH-1200 Tube range: 1/2" to 1 3/4" O.D.
(12.70 to 44.45 mm) O.D.

Expander with 1 1/2" (38.10 mm) long rolls suitable for tube sheet thicknesses from 3/4" to 5 7/8" (19.05 mm to 149.09 mm).

Expander with 2 1/4" (57.15 mm) long rolls suitable for tube sheet thicknesses from 1 1/2" to 6 1/2" (38.10 mm to 165.10 mm).

Special 4 or 5 roll models available.

CH-1200

Model: CH-1200 Long reach with 1 1/2" or 2 1/4" rolls.
Tool reach standard 10" (B) or 12" (C) (254 mm or 305 mm).
Longer reaches available upon request.

Tube range: 1/2" to 1 3/4" (12.70 to 44.45 mm) O.D.

Special 4 or 5 roll models available.

CH-8012

Model: CH-8012 Tube range: 1 3/4" to 4 1/2" O.D.
(44.45 to 114.30 mm) O.D.

Expander with 2 1/4" (57.15 mm) long rolls suitable for tube sheet thicknesses from 1/4" to 4" (6.35 mm to 101.60 mm).

TECO TUBE EXPANDERS

for Condensers and Heat Exchangers

Selection Guide:

Model : CH 900

Tube Size I.D. .155" - .320"
(3.95 - 8.13 mm)

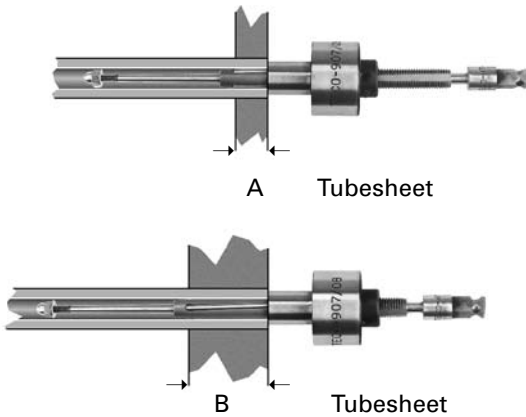

	TUBE SHEET THICKNESS	
	A MINIMUM	B MAXIMUM
TUBE EXPANDER WITH 3/4" ROLL LENGTH	1/8" (3.175 mm)	5/8" (15.87 mm)
TUBE EXPANDER WITH 1 1/4" ROLL LENGTH	1/2" (12.70 mm)	1 9/64" (28.98 mm)

TUBE O.D. AND G.A.	MIN. I.D. TUBE TOOL ENTERS		MAX. TOOL EXPANSION		SIZE SQUARE ON MANDREL	EXPANDER WITH 3/4" (19 mm) ROLLS		EXPANDER WITH 1 1/4" (32 mm) ROLLS		MANDREL NO.
	Inch	mm	Inch	mm		EXPANDER NO.	ROLL SET NO.	EXPANDER NO.	ROLL SET NO.	
1/4"-19	.155	3.95	.190	4.83	1/4"	CH-921	TR-921			MT-40
1/4"-20	.175	4.44	.205	5.21		CH-923	TR-923			MT-40
1/4"-21	.180	4.57	.212	5.38		CH-924	TR-924			MT-40
1/4"-22	.190	4.83	.220	5.59		CH-925	TR-925			MT-41
1/4"-23	.195	4.95	.226	5.74		CH-926	TR-923			MT-41
1/4"-24	.201	5.10	.232	5.92		CH-927	TR-924			MT-41
1/4"-28	.219	5.55	.237	6.02	CH-928	TR-903			MT-928	
3/8"-14	.199	5.05	.232	5.88	1/4"	CH-914	TR-914			MT-35
3/8"-15	.230	5.84	.265	6.73		CH-915	TR-915			MT-36
3/8"-16	.242	6.15	.275	6.98		CH-916	TR-916			MT-36
3/8"-16	.242	6.15	.280	7.11				CH-916-L	TR-916-L	MT-36-L
3/8"-17	.255	6.48	.289	7.34		CH-918	TR-903			MT-37
3/8"-18	.272	6.85	.307	7.80		CH-901	TR-903	CH-902	TR-904	MT-30
3/8"-19	.286	7.26	.320	8.12		CH-903	TR-903	CH-904	TR-904	MT-31
3/8"-20	.300	7.62	.334	8.48		CH-905	TR-907	CH-906	TR-908	MT-32
3/8"-21	.306	7.77	.340	8.61		CH-907	TR-907	CH-908	TR-908	MT-33
3/8"-22	.314	7.98	.349	8.86		CH-909	TR-909	CH-910	TR-910	MT-34
3/8"-23	.320	8.13	.357	9.08		CH-911	TR-911	CH-912	TR-912	MT-34
3/8"-24	.320	8.13	.357	9.08		CH-911	TR-911	CH-912	TR-912	MT-34

TECO TUBE EXPANDERS

for Condensers and Heat Exchangers

Selection Guide:

Model : CH 1300

Tube Size I.D. .230" - .320"
 (5.84 - 8.13 mm)

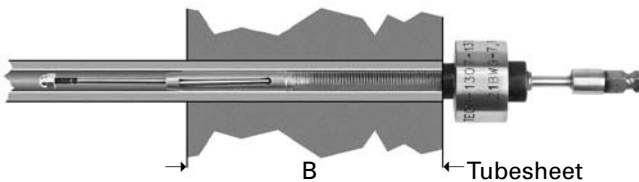
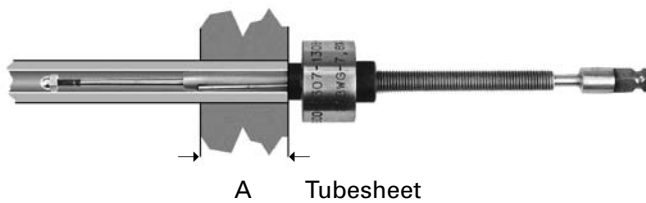

	TUBE SHEET THICKNESS	
	A MINIMUM	B MAXIMUM
TUBE EXPANDER WITH 3/4" ROLL LENGTH	1/4" (6.35 mm)	2 7/8" (73.03 mm)
TUBE EXPANDER WITH 1 1/4" ROLL LENGTH	3/4" (19.05 mm)	3 11/32" (84.93 mm)

TUBE O.D. AND G.A.	MIN. I.D. TUBE TOOL ENTERS		MAX. TOOL EXPANSION		SIZE SQUARE ON MANDREL	EXPANDER WITH 3/4" (19 mm) ROLLS		EXPANDER WITH 1 1/4" (32 mm) ROLLS		MANDREL NO.
	Inch	mm	Inch	mm		EXPANDER NO.	ROLL SET NO.	EXPANDER NO.	ROLL SET NO.	
3/8"-15	.230	5.84	.265	6.73	1/4"	CH-1301 CH-1303 CH-1305	TR-903 TR-903 TR-907	CH-1316	TR-1316	MT-86
3/8"-18	.270	6.85	.307	7.80				CH-1302	TR-904	MT-80
3/8"-19	.286	7.26	.320	8.12				CH-1304	TR-904	MT-81
3/8"-20	.300	7.62	.334	8.48				CH-1306	TR-908	MT-82
3/8"-21	.306	7.77	.340	8.61		CH-1307	TR-907	CH-1308	TR-908	MT-83
3/8"-22	.314	7.98	.349	8.86		CH-1309	TR-909	CH-1310	TR-910	MT-84
3/8"-23	.320	8.13	.357	9.08		CH-1311	TR-911	CH-1312	TR-912	MT-84
3/8"-24	.320	8.13	.357	9.08		CH-1311	TR-911	CH-1312	TR-912	MT-84

TECO TUBE EXPANDERS

for Condensers and Heat Exchangers

Selection Guide:

Model : CH 800

Tube Size I.D. .335" - 1.457"
(8.5 - 37.0 mm)

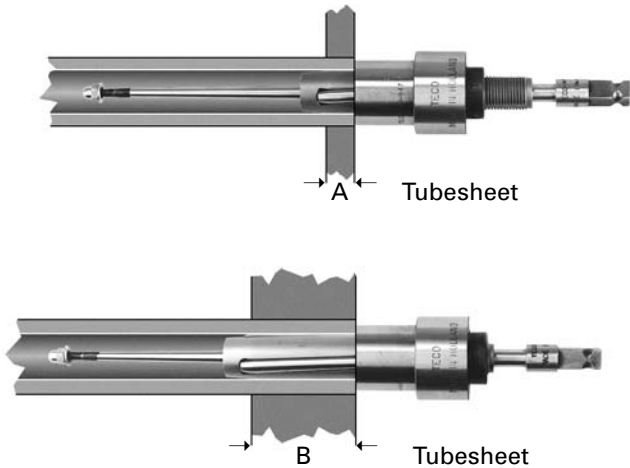

	TUBE SHEET THICKNESS	
	A MINIMUM	B MAXIMUM
TUBE EXPANDER WITH 1 1/2" ROLL LENGTH	1/4" (6.35 mm)	1 1/4" (31.75 mm)
TUBE EXPANDER WITH 2 1/4" ROLL LENGTH	1" (25.40 mm)	2" (50.80 mm)

TUBE O.D. AND G.A.	MIN. I.D. TUBE TOOL ENTERS		MAX. TOOL EXPANSION		SIZE SQUARE ON MANDREL	EXPANDER WITH 1 1/2" (38.1 mm) ROLLS		EXPANDER WITH 2 1/4" (57.1 mm) ROLLS		MANDREL NO.
	Inch	mm	Inch	mm		EXPANDER NO.	ROLL SET NO.	EXPANDER NO.	ROLL SET NO.	
1/2"-14	.324	8.23	.374	9.50	3/8"	CH-797	TR-797			MT-797
1/2"-15	.349	8.86	.398	10.11		CH-799	TR-1			MT-799
1/2"-16	.360	9.14	.410	10.41		CH-801	TR-1			MT-1
1/2"-17	.374	9.50	.424	10.77		CH-803	TR-2			MT-1
1/2"-18	.392	9.96	.447	11.35		CH-805	TR-3			MT-2
5/8"-12	.392	9.96	.447	11.35	3/8"	CH-805	TR-3			MT-2
5/8"-13	.425	10.79	.480	12.19		CH-807	TR-4			MT-3
5/8"-14	.449	11.40	.509	12.73		CH-809	TR-4	CH-810	TR-4-A	MT-4
5/8"-15	.471	11.96	.536	13.61		CH-811	TR-5	CH-812	TR-5-A	MT-5
5/8"-16	.485	12.32	.550	13.97		CH-813	TR-6	CH-814	TR-6-A	MT-5
5/8"-17	.499	12.67	.564	14.32		CH-815	TR-6	CH-816	TR-6-A	MT-6
5/8"-18	.517	13.13	.572	14.53		CH-817	TR-7	CH-818	TR-7-A	MT-7
3/4"-10	.471	11.96	.536	13.61	3/8"	CH-811	TR-5	CH-812	TR-5-A	MT-5
3/4"-11	.499	12.67	.564	14.32		CH-815	TR-6	CH-816	TR-6-A	MT-6
3/4"-12	.522	13.30	.582	15.20		CH-819-N	TR-7	CH-820-N	TR-7-A	MT-8
3/4"-13	.550	13.97	.615	15.62		CH-821	TR-8	CH-822	TR-8-A	MT-8
3/4"-14	.574	14.58	.639	16.23		CH-823	TR-9	CH-824	TR-9-A	MT-8
3/4"-15	.596	15.14	.661	16.79		CH-825	TR-10	CH-826	TR-10-A	MT-8
3/4"-16	.605	15.37	.685	17.40		CH-827	TR-10	CH-828	TR-10-A	MT-9
3/4"-17	.619	15.72	.699	17.75		CH-829	TR-11	CH-830	TR-11-A	MT-9
3/4"-18	.619	15.72	.699	17.75		CH-829	TR-11	CH-830	TR-11-A	MT-9

Note: Expander CH 800 is also available as four or five roll expander see page 10-11.



MACTECH AUSTRALIA HEAD OFFICE:

Unit 2, 52 Vinnicombe Drive, Canningvale, Perth, WA, Australia. 6155
 www.mactechaustralia.com.au • alan@mactechaustralia.com.au

Ph: +61 (08) 9455 6677
 Mob/cell: 0409 081 343
 Fax: +61 (08) 9455 6644

TUBE O.D. AND G.A.	MIN. I.D. TUBE TOOL ENTERS		MAX. TOOL EXPANSION		SIZE SQUARE ON MANDREL	EXPANDER WITH 1 1/2" (38.1 mm) ROLLS		EXPANDER WITH 2 1/4" (57.1 mm) ROLLS		MANDREL NO.
	Inch	mm	Inch	mm		EXPANDER NO.	ROLL SET NO.	EXPANDER NO.	ROLL SET NO.	
7/8"-10	.596	15.14	.661	16.79	3/8"	CH-825	TR-10	CH-826	TR-10-A	MT-8
7/8"-11	.619	15.72	.699	17.75		CH-829	TR-11	CH-830	TR-11-A	MT-9
7/8"-12	.642	16.31	.722	18.34		CH-831	TR-12	CH-832	TR-12-A	MT-9
7/8"-13	.670	17.02	.750	19.05		CH-833	TR-13	CH-834	TR-13-A	MT-10
7/8"-14	.685	17.40	.774	19.66		CH-835	TR-14	CH-836	TR-14-A	MT-11
7/8"-15	.712	18.08	.801	20.34		CH-837	TR-15	CH-838	TR-15-A	MT-11
7/8"-16	.726	18.44	.815	20.70		CH-839	TR-15	CH-840	TR-15-A	MT-12
7/8"-17	.740	18.80	.829	21.06		CH-843	TR-16	CH-844	TR-16-A	MT-12
7/8"-18	.740	18.80	.829	21.06		CH-843	TR-16	CH-844	TR-16-A	MT-12
1" - 8	.655	16.64	.735	18.67		3/8"	CH-841	TR-13	CH-842	TR-13-A
1" - 9	.685	17.40	.774	19.66	CH-835		TR-14	CH-836	TR-14-A	MT-11
1" -10	.712	18.08	.801	20.34	CH-837		TR-15	CH-838	TR-15-A	MT-11
1" -11	.740	18.80	.829	21.06	CH-843		TR-16	CH-844	TR-16-A	MT-12
1" -12	.763	19.38	.852	21.64	CH-845		TR-17	CH-846	TR-17-A	MT-12
1" -13	.791	20.09	.880	22.35	CH-847		TR-18	CH-848	TR-18-A	MT-12
1" -14	.810	20.57	.909	23.09	CH-849		TR-18	CH-850	TR-18-A	MT-13
1" -15	.837	21.26	.936	23.77	CH-851		TR-19	CH-852	TR-19-A	MT-13
1" -16	.837	21.26	.936	23.77	CH-851		TR-19	CH-852	TR-19-A	MT-13
1" -17	.865	21.97	.964	24.48	CH-855		TR-21	CH-856	TR-21-A	MT-13
1" -18-20	.865	21.97	.964	24.48	CH-855	TR-21	CH-856	TR-21-A	MT-13	
1 1/8" - 8	.776	19.71	.875	22.22	3/8"	CH-853	TR-20	CH-854	TR-20-A	MT-13
1 1/8" - 9	.810	20.57	.909	23.09		CH-849	TR-18	CH-850	TR-18-A	MT-13
1 1/8" -10	.837	21.26	.936	23.77		CH-851	TR-19	CH-852	TR-19-A	MT-13
1 1/8" -11	.865	21.97	.964	24.48		CH-855	TR-21	CH-856	TR-21-A	MT-13
1 1/8" -12	.883	22.43	.982	24.94	1/2"	CH-857	TR-21	CH-858	TR-21-A	MT-14
1 1/8" -13	.916	23.57	1.015	25.78		CH-859	TR-22	CH-860	TR-22-A	MT-14
1 1/8" -14	.835	23.75	1.044	26.52		CH-861	TR-23	CH-862	TR-23-A	MT-15
1 1/8" -15	.962	24.43	1.071	27.20		CH-863	TR-24	CH-864	TR-24-A	MT-15
1 1/8" -16	.962	24.43	1.071	27.20		CH-863	TR-24	CH-864	TR-24-A	MT-15
1 1/8" -17	.990	25.15	1.099	27.91		CH-867	TR-26	CH-868	TR-26-A	MT-16
1 1/8" -18	.990	25.15	1.099	27.91		CH-867	TR-26	CH-868	TR-26-A	MT-16
1 1/4" - 8	.901	22.88	1.010	25.60		1/2"	CH-865	TR-25	CH-866	TR-25-A
1 1/4" - 9	.935	23.75	1.044	26.52	CH-861		TR-23	CH-862	TR-23-A	MT-15
1 1/4" -10	.962	24.43	1.071	27.20	CH-863		TR-24	CH-864	TR-24-A	MT-15
1 1/4" -11	.990	25.15	1.099	27.91	CH-867		TR-26	CH-868	TR-26-A	MT-16
1 1/4" -12	1.013	25.73	1.122	28.50	CH-869		TR-27	CH-870	TR-27-A	MT-16
1 1/4" -13	1.041	26.44	1.150	29.21	CH-871		TR-28	CH-872	TR-28-A	MT-17
1 1/4" -14	1.060	26.92	1.169	29.69	CH-873		TR-29	CH-874	TR-29-A	MT-17
1 1/4" -15	1.087	27.61	1.196	30.38	CH-875		TR-30	CH-876	TR-30-A	MT-17
1 1/4" -16	1.087	27.61	1.196	30.38	CH-875		TR-30	CH-876	TR-30-A	MT-17
1 3/8" - 8	1.026	26.06	1.135	28.83	1/2"		CH-877	TR-31	CH-878	TR-31-A
1 3/8" - 9	1.060	26.92	1.169	29.69		CH-873	TR-29	CH-874	TR-29-A	MT-17
1 3/8" -10	1.087	27.61	1.196	30.38		CH-875	TR-30	CH-876	TR-30-A	MT-17
1 3/8" -11	1.115	28.32	1.224	31.09		CH-879	TR-30	CH-880	TR-30-A	MT-18
1 3/8" -12	1.133	28.78	1.242	31.55		CH-881	TR-32	CH-882	TR-32-A	MT-18
1 3/8" -13	1.160	29.46	1.275	32.38		CH-883	TR-33	CH-884	TR-33-A	MT-19
1 3/8" -14	1.179	29.95	1.294	32.87		CH-885	TR-34	CH-886	TR-34-A	MT-20
1 3/8" -15	1.206	30.63	1.321	33.55		CH-887	TR-35	CH-888	TR-35-A	MT-20
1 3/8" -16	1.206	30.63	1.321	33.55		CH-887	TR-35	CH-888	TR-35-A	MT-20
1 1/2" - 8	1.145	29.08	1.260	32.00		1/2"	CH-889	TR-34	CH-890	TR-34-A
1 1/2" - 9	1.179	29.95	1.294	32.87	CH-885		TR-34	CH-886	TR-34-A	MT-20
1 1/2" -10	1.206	30.63	1.321	33.55	CH-887		TR-35	CH-888	TR-35-A	MT-20
1 1/2" -11	1.235	31.37	1.350	34.29	CH-891		TR-36	CH-892	TR-36-A	MT-20
1 1/2" -12	1.257	31.93	1.372	34.85	CH-893		TR-37	CH-894	TR-37-A	MT-20
1 1/2" -13	1.285	32.64	1.400	35.56	CH-895		TR-37	CH-896	TR-37-A	MT-21
1 1/2" -14	1.285	32.64	1.400	35.56	CH-895		TR-37	CH-896	TR-37-A	MT-21
1 1/2" -15	1.331	33.81	1.446	36.73	CH-897		TR-38	CH-898	TR-38-A	MT-21
1 1/2" -16	1.331	33.81	1.446	36.73	CH-897		TR-38	CH-898	TR-38-A	MT-21
1 3/4" - 8	1.406	35.70	1.531	38.90	1/2"		CH-899	TR-38	CH-899RL	TR-38-A

Note: Expander CH 800 is also available as four or five roll expander see page 10-11.

TECO TUBE EXPANDERS

for Condensers and Heat Exchangers

Selection Guide:

Model : CH 800
five roll type
expander

Tube Size I.D. .500" - 1.457"
(12.7 - 37.0 mm)

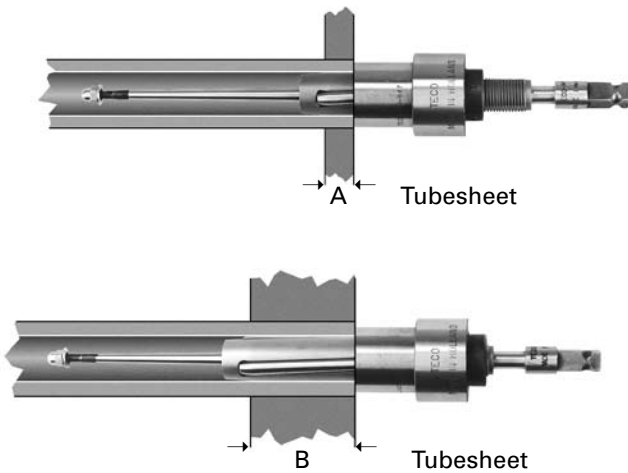

	TUBE SHEET THICKNESS	
	A MINIMUM	B MAXIMUM
TUBE EXPANDER WITH 1 1/2" ROLL LENGTH	1/4" (6.35 mm)	1 1/4" (31.75 mm)
TUBE EXPANDER WITH 2 1/4" ROLL LENGTH	1" (25.40 mm)	2" (50.80 mm)

TUBE O.D. AND G.A.	MIN. I.D. TUBE TOOL ENTERS		MAX. TOOL EXPANSION		SIZE SQUARE ON MANDREL	EXPANDER WITH 1 1/2" (38.1 mm) ROLLS		EXPANDER WITH 2 1/4" (57.1 mm) ROLLS		MANDREL NO.
	Inch	mm	Inch	mm		EXPANDER NO.	ROLL SET NO.	EXPANDER NO.	ROLL SET NO.	
5/8" -17-19	.499	12.67	.578	14.69	3/8"	CH-815-5	TR-4-5	CH-816-5	TR-4-A-5	MT-9
5/8" -20-22	.539	13.70	.601	15.27		CH-819-5	TR-4-5	CH-820-5	TR-4-A-5	MT-11
5/8" -23-24	.550	13.97	.627	15.93		CH-821-5	TR-5-5	CH-822-5	TR-5-A-5	MT-12
3/4" -13-14	.550	13.97	.627	15.93	3/8"	CH-821-5	TR-5-5	CH-822-5	TR-5-A-5	MT-12
3/4" -15-16	.596	15.14	.688	17.21		CH-827-5	TR-8-5	CH-828-5	TR-8-A-5	MT-12
3/4" -17-18	.619	15.72	.706	17.94		CH-829-5	TR-8-5	CH-830-5	TR-8-A-5	MT-13
3/4" -19-21	.642	16.31	.730	18.56	1/2"	CH-831-5	TR-9-5	CH-832-5	TR-9-A-5	MT-13
3/4" -22-24	.670	17.02	.750	19.05		CH-833-5	TR-9-5	CH-834-5	TR-9-A-5	MT-14

Note: For TECO four and five roll expanders we recommend a thin wall thrust collar, especially for 19-24 Gauge wall.



MACTECH AUSTRALIA HEAD OFFICE:

Unit 2, 52 Vinnicombe Drive, Canningvale, Perth, WA, Australia. 6155
 www.mactechaustralia.com.au • alan@mactechaustralia.com.au

Ph: +61 (08) 9455 6677

Mob/cell: 0409 081 343
 Fax: +61 (08) 9455 6644

TECO



TUBE O.D. AND G.A.	MIN. I.D. TUBE TOOL ENTERS		MAX. TOOL EXPANSION		SIZE SQUARE ON MAN- DREL	EXPANDER WITH 1 1/2" (38.1 mm) ROLLS		EXPANDER WITH 2 1/4" (57.1 mm) ROLLS		MANDREL NO.
	Inch	mm	Inch	mm		EXPANDER NO.	ROLL SET NO.	EXPANDER NO.	ROLL SET NO.	
7/8"-13	.670	17.02	.750	19.05	1/2"	CH-833-5	TR-9-5	CH-834-5	TR-9-A-5	MT-14
7/8"-14	.685	17.40	.770	19.56		CH-835-5	TR-10-5	CH-836-5	TR-10-A-5	MT-14
7/8"-15-16	.712	18.08	.807	20.50		CH-837-5	TR-11-5	CH-838-5	TR-11-A-5	MT-16
7/8"-17-18	.740	18.80	.826	20.98		CH-843-5	TR-11-5	CH-844-5	TR-11-A-5	MT-17
7/8"-19-22	.763	19.38	.848	21.65		CH-845-5	TR-12-5	CH-846-5	TR-12-A-5	MT-17
7/8"-23-24	.791	20.09	.892	22.65		CH-847-5	TR-13-5	CH-848-5	TR-13-A-5	MT-18
1"-12	.763	19.38	.848	21.65	1/2"	CH-845-5	TR-12-5	CH-846-5	TR-12-A-5	MT-17
1"-13	.791	20.09	.892	22.65		CH-847-5	TR-13-5	CH-848-5	TR-13-A-5	MT-18
1"-14	.810	20.57	.904	22.97		CH-849-5	TR-14-5	CH-850-5	TR-14-A-5	MT-18
1"-15-16	.837	21.26	.933	23.69		CH-851-5	TR-15-5	CH-852-5	TR-15-A-5	MT-18
1"-17-20	.865	21.97	.971	24.67		CH-855-5	TR-15-5	CH-856-5	TR-15-A-5	MT-20
1"-21-24	.883	22.43	.999	25.38		CH-857-5	TR-15-5	CH-858-5	TR-15-A-5	MT-21
1 1/8"-11	.865	21.97	.971	24.67	1/2"	CH-855-5	TR-15-5	CH-856-5	TR-15-A-5	MT-20
1 1/8"-12	.883	22.43	.999	25.38		CH-857-5	TR-15-5	CH-858-5	TR-15-A-5	MT-21
1 1/8"-13-14	.916	23.57	1.013	25.74		CH-859-5	TR-16-5	CH-860-5	TR-16-A-5	MT-21
1 1/8"-15-16	.962	24.43	1.064	27.02		CH-863-5	TR-18-5	CH-864-5	TR-18-A-5	MT-21
1 1/8"-17-20	.990	25.15	1.091	27.72		CH-867-5	TR-19-5	CH-868-5	TR-19-A-5	MT-21
1 1/8"-21-24	1.013	25.73	1.118	28.40		CH-869-5	TR-21-5	CH-870-5	TR-21-A-5	MT-21
1 1/4"-10	.962	24.43	1.064	27.02	1/2"	CH-863-5	TR-18-5	CH-864-5	TR-18-A-5	MT-21
1 1/4"-11	.990	25.15	1.091	27.72		CH-867-5	TR-19-5	CH-868-5	TR-19-A-5	MT-21
1 1/4"-12	1.013	25.73	1.118	28.40		CH-869-5	TR-21-5	CH-870-5	TR-21-A-5	MT-21
1 1/4"-15-16	1.087	27.61	1.204	30.58		CH-875-5	TR-21-5	CH-876-5	TR-21-A-5	MT-22
1 1/4"-17-22	1.115	28.32	1.259	31.98		CH-879-5	TR-23-5	CH-880-5	TR-23-A-5	MT-22
1 1/4"-23-25	1.133	28.78	1.285	32.64		CH-881-5	TR-24-5	CH-882-5	TR-24-A-5	MT-22
1 3/8"-12	1.133	28.78	1.285	32.64	1/2"	CH-881-5	TR-24-5	CH-882-5	TR-24-A-5	MT-22
1 3/8"-14	1.179	29.95	1.294	32.88		CH-885-5	TR-23-5	CH-886-5	TR-23-A-5	MT-23
1 1/2"-12	1.257	31.93	1.375	34.92	1/2"	CH-893-5	TR-26-5	CH-894-5	TR-26-A-5	MT-24
1 1/2"-17-24	1.374	34.90	1.505	38.22		CH-899-5	TR-29-5	CH-899-RL-5	TR-29-A-5	MT-25

Also available as four roll expander, sizes as five roll expanders.

Note: For TECO four and five roll expanders we recommend a thin wall thrust collar, especially for 19-24 Gauge wall.

TECO TUBE EXPANDERS

for Condensers and Heat Exchangers

Selection Guide:

Model : CH 1200

Tube Size I.D. .335" - 1.457"
 (8.5 - 37.0 mm)

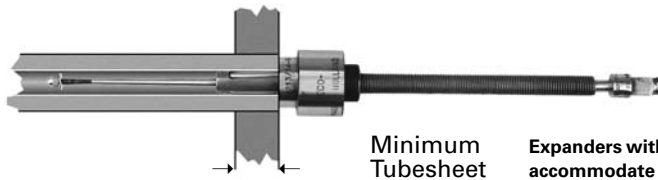

Minimum Tubesheet

Expanders with 1 1/2" (38.1mm) long rolls will accommodate tube sheet thickness as follows:

STANDARD REACH....	3/4" to 5 7/8"	(19.05 mm to 149.22 mm)
"B" REACH....	3/4" to 10"	(19.05 mm to 254.00 mm)
"C" REACH....	3/4" to 12"	(19.05 mm to 304.80 mm)



Maximum Tubesheet

Expanders with 2 1/4" (57.1mm) long rolls will accommodate tube sheet thickness as follows:

STANDARD REACH....	1 1/2" to 6 1/2"	(38.1 mm to 165.10 mm)
"B" REACH....	1 1/2" to 10 3/4"	(38.1 mm to 273.05 mm)
"C" REACH....	1 1/2" to 12 3/4"	(38.1 mm to 323.85 mm)

Longer reaches available upon request in 2 inch (50.8 mm) increments.

TUBE O.D. AND G.A.	MIN. I.D. TUBE TOOL ENTERS		MAX. TOOL EXPANSION		SIZE SQUARE ON MANDREL	EXPANDER WITH 1 1/2" (38.1 mm) ROLLS		EXPANDER WITH 2 1/4" (57.1 mm) ROLLS		MANDREL NO.
	Inch	mm	Inch	mm		EXPANDER NO.	ROLL SET NO.	EXPANDER NO.	ROLL SET NO.	
1/2"-14	.324	8.23	.374	9.50	3/8"	CH-1197	TR-797			MT-1197
1/2"-15	.349	8.86	.398	10.11		CH-1199	TR-1			MT-1199
1/2"-16	.360	9.14	.410	10.41		CH-1201	TR-1			MT-51
1/2"-17	.374	9.50	.424	10.77		CH-1203	TR-2			MT-51
1/2"-18	.392	9.96	.447	11.35		CH-1205	TR-3			MT-52
5/8"-12	.392	9.96	.447	11.35	3/8"	CH-1205	TR-3			MT-52
5/8"-13	.425	10.79	.480	12.19		CH-1207	TR-4			MT-53
5/8"-14	.449	11.40	.509	12.73		CH-1209	TR-4	CH-1210	TR-4-A	MT-54
5/8"-15	.471	11.96	.536	13.61		CH-1211	TR-5	CH-1212	TR-5-A	MT-55
5/8"-16	.485	12.32	.550	13.97		CH-1213	TR-6	CH-1214	TR-6-A	MT-55
5/8"-17	.499	12.67	.564	14.32		CH-1215	TR-6	CH-1216	TR-6-A	MT-56
5/8"-18	.517	13.13	.572	14.53		CH-1217	TR-7	CH-1218	TR-7-A	MT-57
3/4"-10	.471	11.96	.536	13.61		3/8"	CH-1211	TR-5	CH-1212	TR-5-A
3/4"-11	.499	12.67	.564	14.32	CH-1215		TR-6	CH-1216	TR-6-A	MT-56
3/4"-12	.522	13.30	.582	15.20	CH-1219-N		TR-7	CH-1220-N	TR-7-A	MT-58
3/4"-13	.550	13.97	.615	15.62	CH-1221		TR-8	CH-1222	TR-8-A	MT-58
3/4"-14	.574	14.58	.639	16.23	CH-1223		TR-9	CH-1224	TR-9-A	MT-58
3/4"-15	.596	15.14	.661	16.79	CH-1225		TR-10	CH-1226	TR-10-A	MT-58
3/4"-16	.605	15.37	.685	17.40	CH-1227		TR-10	CH-1228	TR-10-A	MT-59
3/4"-17	.619	15.72	.699	17.75	CH-1229		TR-11	CH-1230	TR-11-A	MT-59
3/4"-18	.619	15.72	.699	17.75	CH-1229		TR-11	CH-1230	TR-11-A	MT-59

Note: Expander CH 1200 is also available as four or five roll expander see page 14-15.



MACTECH AUSTRALIA HEAD OFFICE:

Unit 2, 52 Vinnicombe Drive, Canningvale, Perth, WA, Australia. 6155
 www.mactechaustralia.com.au • alan@mactechaustralia.com.au

Ph: +61 (08) 9455 6677

Mob/cell: 0409 081 343

Fax: +61 (08) 9455 6644

TUBE O.D. AND G.A.	MIN. I.D. TUBE TOOL ENTERS		MAX. TOOL EXPANSION		SIZE SQUARE ON MANDREL	EXPANDER WITH 1 1/2" (38.1 mm) ROLLS		EXPANDER WITH 2 1/4" (57.1 mm) ROLLS		MANDREL NO.
	Inch	mm	Inch	mm		EXPANDER NO.	ROLL SET NO.	EXPANDER NO.	ROLL SET NO.	
7/8"-10	.596	15.14	.661	16.79	3/8"	CH-1225	TR-10	CH-1226	TR-10-A	MT-58
7/8"-11	.619	15.72	.699	17.75		CH-1229	TR-11	CH-1230	TR-11-A	MT-59
7/8"-12	.642	16.31	.722	18.34		CH-1231	TR-12	CH-1232	TR-12-A	MT-59
7/8"-13	.670	17.02	.750	19.05		CH-1233	TR-13	CH-1234	TR-13-A	MT-60
7/8"-14	.685	17.40	.774	19.66		CH-1235	TR-14	CH-1236	TR-14-A	MT-61
7/8"-15	.712	18.08	.801	20.34		CH-1237	TR-15	CH-1238	TR-15-A	MT-61
7/8"-16	.726	18.44	.815	20.70		CH-1239	TR-15	CH-1240	TR-15-A	MT-62
7/8"-17	.740	18.80	.829	21.06		CH-1243	TR-16	CH-1244	TR-16-A	MT-62
7/8"-18	.740	18.80	.829	21.06	CH-1243	TR-16	CH-1244	TR-16-A	MT-62	
1" - 8	.655	16.64	.735	18.67	3/8"	CH-1241	TR-13	CH-1242	TR-13-A	MT-59
1" - 9	.685	17.40	.774	19.66		CH-1235	TR-14	CH-1236	TR-14-A	MT-61
1" - 10	.712	18.08	.801	20.34		CH-1237	TR-15	CH-1238	TR-15-A	MT-61
1" - 11	.740	18.80	.829	21.06		CH-1243	TR-16	CH-1244	TR-16-A	MT-62
1" - 12	.763	19.38	.852	21.64		CH-1245	TR-17	CH-1246	TR-17-A	MT-62
1" - 13	.791	20.09	.880	22.35		CH-1247	TR-18	CH-1248	TR-18-A	MT-62
1" - 14	.810	20.57	.909	23.09		CH-1249	TR-18	CH-1250	TR-18-A	MT-63
1" - 15	.837	21.26	.936	23.77		CH-1251	TR-19	CH-1252	TR-19-A	MT-63
1" - 16	.837	21.26	.936	23.77		CH-1251	TR-19	CH-1252	TR-19-A	MT-63
1" - 17	.865	21.97	.964	24.48		CH-1255	TR-21	CH-1256	TR-21-A	MT-63
1" - 18-20	.865	21.97	.964	24.48	CH-1255	TR-21	CH-1256	TR-21-A	MT-63	
1 1/8" - 8	.776	19.71	.875	22.22	3/8"	CH-1253	TR-20	CH-1254	TR-20-A	MT-63
1 1/8" - 9	.810	20.57	.909	23.09		CH-1249	TR-18	CH-1250	TR-18-A	MT-63
1 1/8" - 10	.837	21.26	.936	23.77		CH-1251	TR-19	CH-1252	TR-19-A	MT-63
1 1/8" - 11	.865	21.97	.964	24.48		CH-1255	TR-21	CH-1256	TR-21-A	MT-63
1 1/8" - 12	.883	22.43	.982	24.94	1/2"	CH-1257	TR-21	CH-1258	TR-21-A	MT-64
1 1/8" - 13	.916	23.57	1.015	25.78		CH-1259	TR-22	CH-1260	TR-22-A	MT-64
1 1/8" - 14	.835	23.75	1.044	26.52		CH-1261	TR-23	CH-1262	TR-23-A	MT-65
1 1/8" - 15	.962	24.43	1.071	27.20		CH-1263	TR-24	CH-1264	TR-24-A	MT-65
1 1/8" - 16	.962	24.43	1.071	27.20		CH-1263	TR-24	CH-1264	TR-24-A	MT-65
1 1/8" - 17	.990	25.15	1.099	27.91		CH-1267	TR-26	CH-1268	TR-26-A	MT-66
1 1/8" - 18	.990	25.15	1.099	27.91		CH-1267	TR-26	CH-1268	TR-26-A	MT-66
1 1/4" - 8	.901	22.88	1.010	25.60		1/2"	CH-1265	TR-25	CH-1266	TR-25-A
1 1/4" - 9	.935	23.75	1.044	26.52	CH-1261		TR-23	CH-1262	TR-23-A	MT-65
1 1/4" - 10	.962	24.43	1.071	27.20	CH-1263		TR-24	CH-1264	TR-24-A	MT-65
1 1/4" - 11	.990	25.15	1.099	27.91	CH-1267		TR-26	CH-1268	TR-26-A	MT-66
1 1/4" - 12	1.013	25.73	1.122	28.50	CH-1269		TR-27	CH-1270	TR-27-A	MT-66
1 1/4" - 13	1.041	26.44	1.150	29.21	CH-1271		TR-28	CH-1272	TR-28-A	MT-67
1 1/4" - 14	1.060	26.92	1.169	29.69	CH-1273		TR-29	CH-1274	TR-29-A	MT-67
1 1/4" - 15	1.087	27.61	1.196	30.38	CH-1275		TR-30	CH-1276	TR-30-A	MT-67
1 1/4" - 16	1.087	27.61	1.196	30.38	CH-1275		TR-30	CH-1276	TR-30-A	MT-67
1 3/8" - 8	1.026	26.06	1.135	28.83	1/2"		CH-1277	TR-31	CH-1278	TR-31-A
1 3/8" - 9	1.060	26.92	1.169	29.69		CH-1273	TR-29	CH-1274	TR-29-A	MT-67
1 3/8" - 10	1.087	27.61	1.196	30.38		CH-1275	TR-30	CH-1276	TR-30-A	MT-67
1 3/8" - 11	1.115	28.32	1.224	31.09		CH-1279	TR-30	CH-1280	TR-30-A	MT-68
1 3/8" - 12	1.133	28.78	1.242	31.55		CH-1281	TR-32	CH-1282	TR-32-A	MT-68
1 3/8" - 13	1.160	29.46	1.275	32.38		CH-1283	TR-33	CH-1284	TR-33-A	MT-69
1 3/8" - 14	1.179	29.95	1.294	32.87		CH-1285	TR-34	CH-1286	TR-34-A	MT-70
1 3/8" - 15	1.206	30.63	1.321	33.55		CH-1287	TR-35	CH-1288	TR-35-A	MT-70
1 3/8" - 16	1.206	30.63	1.321	33.55		CH-1287	TR-35	CH-1288	TR-35-A	MT-70
1 1/2" - 8	1.145	29.08	1.260	32.00		1/2"	CH-1289	TR-34	CH-1290	TR-34-A
1 1/2" - 9	1.179	29.95	1.294	32.87	CH-1285		TR-34	CH-1286	TR-34-A	MT-70
1 1/2" - 10	1.206	30.63	1.321	33.55	CH-1287		TR-35	CH-1288	TR-35-A	MT-70
1 1/2" - 11	1.235	31.37	1.350	34.29	CH-1291		TR-36	CH-1292	TR-36-A	MT-70
1 1/2" - 12	1.257	31.93	1.372	34.85	CH-1293		TR-37	CH-1294	TR-37-A	MT-70
1 1/2" - 13	1.285	32.64	1.400	35.56	CH-1295		TR-37	CH-1296	TR-37-A	MT-71
1 1/2" - 14	1.285	32.64	1.400	35.56	CH-1295		TR-37	CH-1296	TR-37-A	MT-71
1 1/2" - 15	1.331	33.81	1.446	36.73	CH-1297		TR-38	CH-1298	TR-38-A	MT-71
1 1/2" - 16	1.331	33.81	1.446	36.73	CH-1297		TR-38	CH-1298	TR-38-A	MT-71
1 3/4" - 8	1.406	35.70	1.531	38.90	1/2"		CH-1299	TR-38	CH-1299RL	TR-38-A

Note: Expander CH 1200 is also available as four or five roll expander see page 14-15.

TECO TUBE EXPANDERS

for Condensers and Heat Exchangers

Selection Guide:

Model : CH 1200
five roll type
expander

Tube Size I.D. .500" - 1.457"
(12.7 - 37.0 mm)

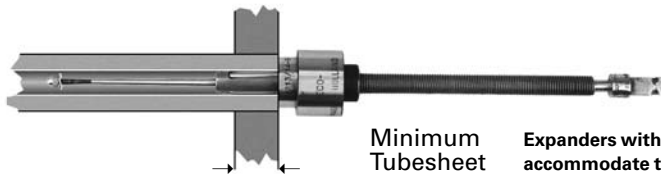

Minimum Tubesheet

Expanders with 1 1/2" (38.1mm) long rolls will accommodate tube sheet thickness as follows:

STANDARD REACH....	3/4" to 5 7/8"	(19.05 mm to 149.22 mm)
"B" REACH....	3/4" to 10"	(19.05 mm to 254.00 mm)
"C" REACH....	3/4" to 12"	(19.05 mm to 304.80 mm)

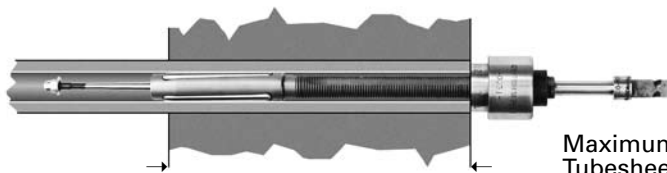

Maximum Tubesheet

Expanders with 2 1/4" (57.1mm) long rolls will accommodate tube sheet thickness as follows:

STANDARD REACH....	1 1/2" to 6 1/2"	(38.1 mm to 165.10 mm)
"B" REACH....	1 1/2" to 10 3/4"	(38.1 mm to 273.05 mm)
"C" REACH....	1 1/2" to 12 3/4"	(38.1 mm to 323.85 mm)

Longer reaches available upon request in 2 inch (50.8 mm) increments.

TUBE O.D. AND G.A.	MIN. I.D. TUBE TOOL ENTERS		MAX. TOOL EXPANSION		SIZE SQUARE ON MANDREL	EXPANDER WITH 1 1/2" (38.1 mm) ROLLS		EXPANDER WITH 2 1/4" (57.1 mm) ROLLS		MANDREL NO.
	Inch	mm	Inch	mm		EXPANDER NO.	ROLL SET NO.	EXPANDER NO.	ROLL SET NO.	
5/8"-17-19	.499	12.67	.578	14.69	3/8"	CH-1215-5	TR- 4-5	CH-1216-5	TR- 4-A-5	MT-59
5/8"-20-22	.539	13.70	.601	15.27		CH-1219-5	TR- 4-5	CH-1220-5	TR- 4-A-5	MT-61
5/8"-23-24	.550	13.97	.627	15.93		CH-1221-5	TR- 5-5	CH-1222-5	TR- 5-A-5	MT-62
3/4"-13-14	.550	13.97	.627	15.93	1/2"	CH-1221-5	TR- 5-5	CH-1222-5	TR- 5-A-5	MT-62
3/4"-15-16	.596	15.14	.688	17.21		CH-1227-5	TR- 8-5	CH-1228-5	TR- 8-A-5	MT-62
3/4"-17-18	.619	15.72	.706	17.94		CH-1229-5	TR- 8-5	CH-1230-5	TR- 8-A-5	MT-63
3/4"-19-21	.642	16.31	.730	18.56		CH-1231-5	TR- 9-5	CH-1232-5	TR- 9-A-5	MT-63
3/4"-22-24	.670	17.02	.750	19.05	CH-1233-5	TR- 9-5	CH-1234-5	TR- 9-A-5	MT-64	

Note: For TECO four and five roll expanders we recommend a thin wall thrust collar, especially for 19-24 Gauge wall.



MACTECH AUSTRALIA HEAD OFFICE:

Unit 2, 52 Vinnicombe Drive, Canningvale, Perth, WA, Australia. 6155
 www.mactechaustralia.com.au • alan@mactechaustralia.com.au

Ph: +61 (08) 9455 6677

Mob/cell: 0409 081 343

Fax: +61 (08) 9455 6644



TECO

TUBE O.D. AND G.A.	MIN. I.D. TUBE TOOL ENTERS		MAX. TOOL EXPANSION		SIZE SQUARE ON MAN- DREL	EXPANDER WITH 1 1/2" (38.1 mm) ROLLS		EXPANDER WITH 2 1/4" (57.1 mm) ROLLS		MANDREL NO.		
	Inch	mm	Inch	mm		EXPANDER NO.	ROLL SET NO.	EXPANDER NO.	ROLL SET NO.			
7/8"-13 7/8"-14 7/8"-15-16	.670 .685 .712	17.02 17.40 18.08	.750 .770 .807	19.05 19.56 20.50	1/2"	CH-1233-5 CH-1235-5 CH-1237-5	TR-9-5 TR-10-5 TR-11-5	CH-1234-5 CH-1236-5 CH-1238-5	TR-9-A-5 TR-10-A-5 TR-11-A-5	MT-64 MT-64 MT-66		
7/8"-17-18 7/8"-19-22 7/8"-23-24	.740 .763 .791	18.80 19.38 20.09	.826 .848 .892	20.98 21.65 22.65		CH-1243-5 CH-1245-5 CH-1247-5	TR-11-5 TR-12-5 TR-13-5	CH-1244-5 CH-1246-5 CH-1248-5	TR-11-A-5 TR-12-A-5 TR-13-A-5	MT-67 MT-67 MT-68		
1"-12 1"-13 1"-14	.763 .791 .810	19.38 20.09 20.57	.848 .892 .904	21.65 22.65 22.97		1/2"	CH-1245-5 CH-1247-5 CH-1249-5	TR-12-5 TR-13-5 TR-14-5	CH-1246-5 CH-1248-5 CH-1250-5	TR-12-A-5 TR-13-A-5 TR-14-A-5	MT-67 MT-68 MT-68	
1"-15-16 1"-17-20 1"-21-24	.837 .865 .883	21.26 21.97 22.43	.933 .971 .999	23.69 24.67 25.38			CH-1251-5 CH-1255-5 CH-1257-5	TR-15-5 TR-15-5 TR-15-5	CH-1252-5 CH-1256-5 CH-1258-5	TR-15-A-5 TR-15-A-5 TR-15-A-5	MT-68 MT-70 MT-71	
1 1/8"-11 1 1/8"-12 1 1/8"-13-14	.865 .883 .916	21.97 22.43 23.57	.971 .999 1.013	24.67 25.38 25.74			1/2"	CH-1255-5 CH-1257-5 CH-1259-5	TR-15-5 TR-15-5 TR-16-5	CH-1256-5 CH-1258-5 CH-1260-5	TR-15-A-5 TR-15-A-5 TR-16-A-5	MT-70 MT-71 MT-71
1 1/8"-15-16 1 1/8"-17-20 1 1/8"-21-24	.962 .990 1.013	24.43 25.15 25.73	1.064 1.091 1.118	27.02 27.72 28.40				CH-1263-5 CH-1267-5 CH-1269-5	TR-18-5 TR-19-5 TR-21-5	CH-1264-5 CH-1268-5 CH-1270-5	TR-18-A-5 TR-19-A-5 TR-21-A-5	MT-71 MT-71 MT-71
1 1/4"-10 1 1/4"-11 1 1/4"-12	.962 .990 1.013	24.43 25.15 25.73	1.064 1.091 1.118	27.02 27.72 28.40	1/2"			CH-1263-5 CH-1267-5 CH-1269-5	TR-18-5 TR-19-5 TR-21-5	CH-1264-5 CH-1268-5 CH-1270-5	TR-18-A-5 TR-19-A-5 TR-21-A-5	MT-71 MT-71 MT-71
1 1/4"-15-16 1 1/4"-17-22 1 1/4"-23-25	1.087 1.115 1.133	27.61 28.32 28.78	1.204 1.259 1.285	30.58 31.98 32.64				CH-1275-5 CH-1279-5 CH-1281-5	TR-21-5 TR-23-5 TR-24-5	CH-1276-5 CH-1280-5 CH-1282-5	TR-21-A-5 TR-23-A-5 TR-24-A-5	MT-72 MT-72 MT-72
1 3/8"-12 1 3/8"-14	1.133 1.179	28.78 29.95	1.285 1.294	32.64 32.88		1/2"		CH-1281-5 CH-1285-5	TR-24-5 TR-23-5	CH-1282-5 CH-1286-5	TR-24-A-5 TR-23-A-5	MT-72 MT-73
1 1/2"-12 1 1/2"-17-24	1.257 1.374	31.93 34.90	1.375 1.505	34.92 38.22				CH-1293-5 CH-1299-5	TR-26-5 TR-29-5	CH-1294-5 CH-1299-RL-5	TR-26-A-5 TR-29-A-5	MT-74 MT-75

Also available as four roll expander, sizes as five roll expander.

Note: For TECO four and five roll expanders we recommend a thin wall thrust collar, especially for 19-24 Gauge wall.

TECO TUBE EXPANDERS

for Condensers and Heat Exchangers

Selection Guide:

Model : CH 8012

Tube Size I.D. 1.358" - 4.000"
 (34.5 - 101.6 mm)

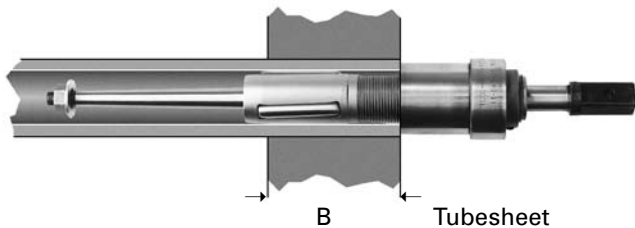
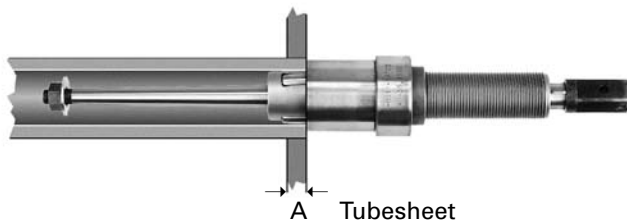

	TUBE SHEET THICKNESS	
	A MINIMUM	B MAXIMUM
TUBE EXPANDER WITH 2 1/4" ROLL LENGTH	1/4" (6.35 mm)	3 3/4" (95.25 mm)

TUBE O.D. AND G.A.	MIN. I.D. TUBE TOOL ENTERS		MAX. TOOL EXPANSION		SIZE SQUARE ON MANDREL	EXPANDER WITH 2 1/4" (57.1 mm) ROLLS		MANDREL NO.
	Inch	mm	Inch	mm		EXPANDER NO.	ROLL SET NO.	
1 3/4" - 8	1.358	34.50	1.552	39.42	3/4"	CH-8012-1 3/4-8	TR-33-A	MT-90
1 3/4" - 9-10	1.420	36.10	1.617	41.08		CH-8012-1 3/4-10	TR-37-A	MT-90
1 3/4" -11	1.452	36.90	1.637	41.58		CH-8012-1 3/4-11	TR-42	MT-90
1 3/4" -12	1.480	37.60	1.659	42.14		CH-8012-1 3/4-12	TR-44	MT-90
1 3/4" -13	1.507	38.30	1.687	42.84		CH-8012-1 3/4-13	TR-46	MT-90
1 3/4" -14	1.532	38.90	1.711	43.46		CH-8012-1 3/4-14	TR-48	MT-90
2" - 6-7	1.563	39.70	1.791	45.51	3/4"	CH-8012-2-6-7	TR-48	MT-91
2" - 8-10	1.625	41.30	1.859	47.23		CH-8012-2-8-10	TR-50	MT-91
2" -11	1.662	42.00	1.888	47.95		CH-8012-2-11	TR-52	MT-91
2" -12	1.685	42.80	1.910	48.51		CH-8012-2-12	TR-54	MT-91
2" -13-16	1.724	43.80	1.949	49.51		CH-8012-2-13-16	TR-56	MT-91
2 1/4" - 5	1.788	45.40	2.019	51.28	3/4"	CH-8012-2 1/4- 5	TR-50	MT-92
2 1/4" - 6- 7	1.839	46.70	2.069	52.56		CH-8012-2 1/4- 6- 7	TR-54	MT-92
2 1/4" -8-10	1.882	47.80	2.109	53.56		CH-8012-2 1/4- 8-10	TR-56	MT-92
2 1/4" -11	1.921	48.50	2.137	54.28		CH-8012-2 1/4-11	TR-58	MT-92
2 1/4" -12	1.933	49.10	2.159	54.84		CH-8012-2 1/4-12	TR-60	MT-92
2 1/4" -13-16	1.936	49.80	2.187	55.56		CH-8012-2 1/4-13-16	TR-62	MT-92

Note: Expander CH 8012 is also available as four or five roll expander.



MACTECH AUSTRALIA HEAD OFFICE:
 Unit 2, 52 Vinnicombe Drive, Canningvale, Perth, WA, Australia. 6155
 www.mactechaustralia.com.au • alan@mactechaustralia.com.au

Ph: +61 (08) 9455 6677
Mob/cell: 0409 081 343
Fax: +61 (08) 9455 6644

TECO



TUBE O.D. AND G.A.	MIN. I.D. TUBE TOOL ENTERS		MAX. TOOL EXPANSION		SIZE SQUARE ON MAN- DREL	EXPANDER WITH 2 1/4" (57.1 mm) ROLLS		MANDREL NO.
	Inch	mm	Inch	mm		EXPANDER NO.	ROLL SET NO.	
2 1/2"-5-7	2.043	51.90	2.348	59.64	1"	CH-8012-2 1/2- 5- 7	TR-62	MT-96
2 1/2"-8-12	2.134	54.20	2.409	61.20	3/4"	CH-8012-2 1/2- 8-12	TR-64	MT-93
2 1/2"-13-16	2.232	56.70	2.437	61.90		CH-8012-2 1/2-13-16	TR-64	MT-94
2 3/4"-5-7	2.291	58.20	2.598	65.98	1"	CH-8012-2 3/4- 5- 7	TR-64	MT-96
2 3/4"-8-14	2.366	60.10	2.673	67.90		CH-8012-2 3/4- 8-14	TR-66	MT-96
3"-3-4	2.449	62.20	2.752	69.90	1"	CH-8012-3-3-4	TR-64	MT-97-SP
3"-5	2.478	62.90	2.791	70.90		CH-8012-3-5	TR-64	MT-98
3"-6-7	2.547	64.70	2.867	72.82		CH-8012-3-6-7	TR-66	MT-98
3"-8-14	2.618	66.50	2.924	74.26		CH-8012-3-8-14	TR-67	MT-96
3 1/4"-5-9	2.744	69.70	3.045	77.35	1"	CH-8012-3 1/4- 5- 9	TR-67	MT-97
3 1/4"-7-14	2.871	72.90	3.174	80.63		CH-8012-3 1/4- 7-14	TR-68	MT-97
3 1/2"-7-13	3.043	77.30	3.361	85.38	1"	CH-8012-3 1/2- 7-13	TR-69	MT-98
3 1/2"-8-14	3.122	79.30	3.440	87.38		CH-8012-3 1/2- 8-14	TR-69	MT-99
3 1/2"-11-18	3.224	81.90	3.543	89.98		CH-8012-3 1/2-11-18	TR-70	MT-99
4"-6-11	3.575	90.80	3.898	99.00	1"	CH-8012-4-6-11	TR-71	MT-99
4"-10-16	3.701	94.00	4.014	100.96		CH-8012-4-10-16	TR-72	MT-99
4"-12-18	3.732	94.80	4.050	102.86		CH-8012-4-12-18	TR-71	MT-100
4 1/4"-8-12	3.851	97.80	4.179	105.76	1"	CH-8012-4 1/4- 8-12	TR-72	MT-100
4 1/2"-2-3	3.851	97.80	4.179	105.76	1"	CH-8012-4 1/2- 2- 3	TR-72	MT-100

Note: Expander CH 8012 is also available as four or five roll expander.

T_{ECO} TBE SERIES BOILER TUBE EXPANDERS

Selection Guide:

Model : TBE

Tube Size I.D. 0.75" - 3.78"
(19 - 96 mm)

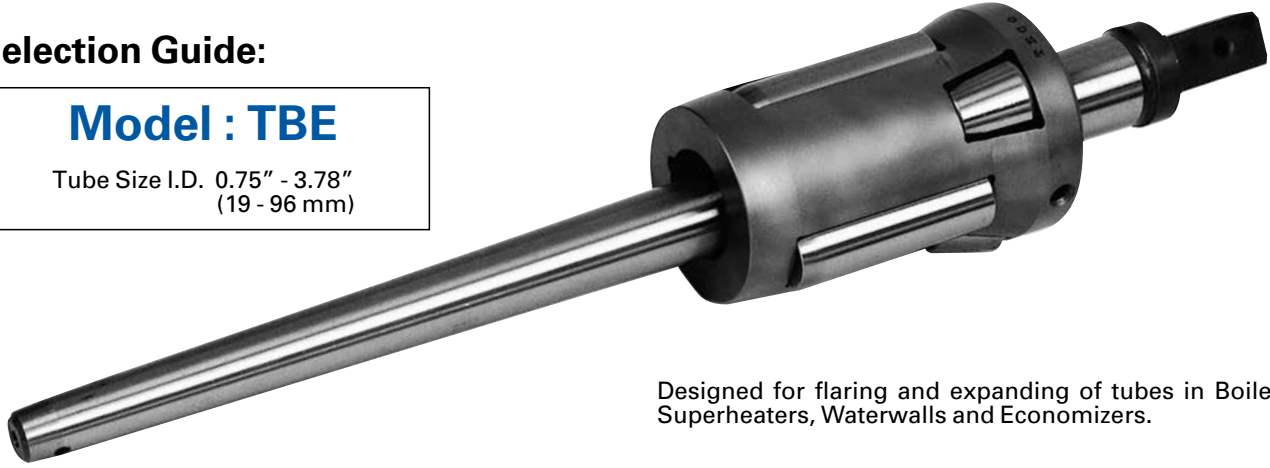

Designed for flaring and expanding of tubes in Boilers, Superheaters, Waterwalls and Economizers.

TOOL NO.	MIN. I.D. TUBE TOOL		MAX. TOOL EXPANSION		STD. ROLL LENGHT O.A.L.		ROLL EXPANSION & FLARE	MANDREL NO.	MANDREL O.A.L.		SHORT MANDREL SET (3 PCS)	SMS O.A.L.		SIZE SQUARE ON MANDREL
	mm	Inch	mm	Inch	mm	Inch			mm	Inch		mm	Inch	
TBE-19	19	0.75	22	0.87	42	1.65	TBR-12	TBM-19	195	7.68				1/2"
TBE-20	20	0.79	23	0.91	42	1.65	TBR-12	TBM-20	195	7.68				1/2"
TBE-22	22	0.87	25	0.98	42	1.65	TBR-12	TBM-22	195	7.68				1/2"
TBE-23	23	0.91	26	1.02	42	1.65	TBR-13	TBM-23	195	7.68				1/2"
TBE-24	24	0.94	27	1.06	42	1.65	TBR-13	TBM-24	195	7.68				1/2"
TBE-25	25	0.98	28	1.10	42	1.65	TBR-13	TBM-25	195	7.68				1/2"
TBE-27	27	1.06	30	1.18	42	1.65	TBR-15	TBM-27	200	7.87				1/2"
TBE-28	28	1.10	32	1.26	42	1.65	TBR-16	TBM-28	260	10.24	TBMS-28	175	6.89	3/4"
TBE-29	29	1.14	33	1.30	42	1.65	TBR-16	TBM-29	260	10.24	TBMS-29	175	6.89	3/4"
TBE-30	30	1.18	34	1.34	42	1.65	TBR-16	TBM-30	260	10.24	TBMS-30	175	6.89	3/4"
TBE-32	32	1.26	36	1.42	42	1.65	TBR-17	TBM-32	260	10.24	TBMS-32	175	6.89	3/4"
TBE-35	35	1.38	41	1.61	42	1.65	TBR-21	TBM-37	310	12.20	TBMS-37	188	7.40	3/4"
TBE-37	37	1.46	43	1.69	42	1.65	TBR-22	TBM-37	310	12.20	TBMS-37	188	7.40	3/4"
TBE-40	40	1.57	46	1.81	50	1.97	TBR-40	TBM-42	310	12.20	TBMS-42	205	8.07	3/4"
TBE-42	42	1.65	48	1.89	50	1.97	TBR-23	TBM-42	310	12.20	TBMS-42	205	8.07	3/4"
TBE-44	44	1.73	50	1.97	50	1.97	TBR-23	TBM-44	310	12.20	TBMS-44	205	8.07	3/4"
TBE-47	47	1.85	54	2.13	50	1.97	TBR-24	TBM-47	338	13.31	TBMS-47	218	8.58	3/4"
TBE-49	49	1.93	56	2.20	50	1.97	TBR-24	TBM-49	338	13.31	TBMS-49	218	8.58	3/4"
TBE-52	52	2.05	59	2.32	50	1.97	TBR-25	TBM-49	338	13.31	TBMS-49	218	8.58	3/4"
TBE-54	54	2.13	62	2.44	50	1.97	TBR-26	TBM-54	375	14.76	TBMS-54	230	9.06	3/4"
TBE-57	57	2.24	66	2.60	50	1.97	TBR-27	TBM-57	395	15.55	TBMS-57	235	9.25	3/4"
TBE-60	60	2.36	69	2.72	50	1.97	TBR-28	TBM-57	395	15.55	TBMS-57	235	9.25	3/4"
TBE-65	65	2.56	74	2.91	50	1.97	TBR-29	TBM-65	395	15.55	TBMS-65	235	9.25	3/4"
TBE-68	68	2.68	78	3.07	50	1.97	TBR-30	TBM-72	425	16.73	TBMS-72	255	10.04	1"
TBE-72	72	2.83	82	3.23	50	1.97	TBR-31	TBM-72	425	16.73	TBMS-72	255	10.04	1"
TBE-77	77	3.03	87	3.43	50	1.97	TBR-32	TBM-77	425	16.73	TBMS-77	255	10.04	1"
TBE-82	82	3.23	92	3.62	50	1.97	TBR-33	TBM-82	425	16.73	TBMS-82	255	10.04	1"
TBE-86	86	3.39	96	3.78	50	1.97	TBR-34	TBM-86	425	16.73	TBMS-86	255	10.04	1"
TBE-90	90	3.54	102	4.02	50	1.97	TBR-34	TBM-90	485	19.09	TBMS-90	275	10.83	1"
TBE-96	96	3.78	108	4.25	50	1.97	TBR-35	TBM-96	485	19.09	TBMS-96	275	10.83	1"

Extra roll length:

TBE-19 up to TBE-27, 30 mm (1.18") OR 50 mm (1.97").

TBE-28 up to TBE-37, 30 mm (1.18") OR 50 mm (1.97") OR 60 mm (2.36") OR 70 mm (2.76").

TBE-40 up to TBE-96, 40 mm (1.57") OR 60 mm (2.36") OR 70 mm (2.76") OR 80 mm (3.15") OR 90 mm (3.54") OR 100 mm (3.94").

Expanders from TBE-35 to TBE-96 have metal roll retainer.

Expanders from TBE-19 to TBE-32 have pin hole rather than metal roll retainer.

If you order expander TBE-54 with rolls of 50 mm you should specify TBE-5450, with 60 mm TBE-5460.

Short mandrel set with shorter length on request.

TECO TUBE EXPANDERS

for Condensers and Heat Exchangers

Selection Guide:

Model : TTR 800

Tube Size I.D. .313" - 1.378"
(7.9 - 35 mm)



TECO TACK Rolling Tube Expander

Conical expander to expand the tube at the tube sheet face, before tube to tubesheet welding.

EXPANDER NO.	MIN. TOOL EXPANSION		MAX. EXPANSION		SIZE SQUARE ON MANDREL	ROLL SET NO.	MANDREL NO.
	Inch	mm	Inch	mm			
TTR-797	.313	7.9	.354	9.0	3/8 "	TR-797	MT-797
TTR-801	.349	8.9	.390	9.9	3/8 "	TR-1	MT-1
TTR-805	.381	9.7	.427	10.8	3/8 "	TR-3	MT-2
TTR-811	.433	11.0	.515	13.1	3/8 "	TR-5	MT-5
TTR-815	.461	11.7	.543	13.8	3/8 "	TR-6	MT-6
TTR-819	.480	12.2	.574	14.6	3/8 "	TR-7	MT-6
TTR-823	.535	13.6	.630	16.0	3/8 "	TR-9	MT-8
TTR-831	.602	15.3	.713	18.1	3/8 "	TR-12	MT-9
TTR-833	.633	16.1	.744	18.9	3/8 "	TR-13	MT-10
TTR-843	.701	17.8	.823	20.9	3/8 "	TR-16	MT-12
TTR-849	.771	19.6	.902	22.9	3/8 "	TR-18	MT-13
TTR-855	.826	21.0	.957	24.3	3/8 "	TR-21	MT-13
TTR-863	.925	23.5	1.063	27.0	1/2 "	TR-24	MT-15
TTR-871	1.004	25.5	1.142	29.0	1/2 "	TR-28	MT-17
TTR-881	1.094	27.8	1.236	31.4	1/2 "	TR-32	MT-18
TTR-885	1.142	29.0	1.284	32.6	1/2 "	TR-34	MT-20
TTR-895	1.248	31.7	1.390	35.3	1/2 "	TR-37	MT-21
TTR-899	1.378	35.0	1.524	38.7	1/2 "	TR-38	MT-22

Expansion range at the middle of roll length.

Note: Expander TTR 800 is also available as four or five roll expander.



MACTECH AUSTRALIA HEAD OFFICE:

Unit 2, 52 Vinnicombe Drive, Canningvale, Perth, WA, Australia. 6155
www.mactechaustralia.com.au • alan@mactechaustralia.com.au

Ph: +61 (08) 9455 6677

Mob/cell: 0409 081 343

Fax: +61 (08) 9455 6644

SPECIAL MODELS OF TUBE EXPANDERS



STEP EXPANDER Model: SL (patented)

Designed to avoid destructive axial stress in welded joints.

Among the many applications is expanding U-tubes in welded joints on thick tube plates, whereby the tubes are expanded after welding.

Automatic axial movement of the expander housing during expansion, ensures that tube elongation developed during this operation, is on the rear side of the tube plate.

The TECO SL Step Expander automatically smooths out the overlapping during expanding.

The range covered is for tubes from 3/8" to 1 11/32" (9 to 34 mm) I.D. and tube sheets thickness 2 9/16" to 27 1/2" (65 to 698.5 mm).

On request the expander can be supplied with Teflon bushings to prevent tube damage.



STEP BY STEP TUBE EXPANDER

This model expander is specially designed for thick tube sheets.

Automatic overlapping of the rolling in stages.

For tubes 3/8" to 1 3/8" (9.5 mm to 34.9 mm) I.D. and tube sheet thickness 2 1/2" to 27 1/2" (63.5 mm to 698.5 mm).



FIVE ROLL EXPANDER Model: CH 800 AND CH 1200

A special line of expanders to expand thin wall tubes, titanium, stainless steel and other high quality metals.

Available with special thrust collars, to eliminate the possibility of the tube being drawn up inside the thrust collar.

Reference pages 10-11 & 14-15.



TUBE EXPANDER Model: CC

Ideal for expanding tubes in thin tube sheets.
For tubes from 1/2" to 4 1/2" (12.7 mm to 114.3 mm) O.D..
Available with adjustable collar.

SPECIAL MODELS OF TUBE EXPANDERS



TUBE EXPANDER Model: SR

Ideally suited for tube rolling with minimum travel of mandrel.
Expander mandrel is retained at rear to shorten mandrel length and to allow use near tube bends or I.D. fixed tubes.



TUBE EXPANDER Model: CL

Specially designed to enlarge the ends of non ferrous or thin steel tubes so that another tube of the same diameter can be inserted and welded or soldered.
All tube sizes covered.
Available with adjustable collar.



TUBE EXPANDER Model: Simplex

Designed for expanding core seals, according to DIN 443, in motor housings, cylinder heads and other cast parts.