

CLAMSHELL PORTABLE LATHES

MACTECH PORTABLE MACHINING SOLUTIONS

Cold Cut and Bevel Pipe

Mactech's **Clamshell lathes** are portable pipe cutting machines for in situ precision cutting and beveling of all pipe sizes, schedules and materials. Our line covers a wide range of pipe sizes from 2" to 60" OD and are designed so that minimal radial and axial clearance is required for easy installation on in-line closed loop pipe.

Mactech models available for rent or purchase:

LC Clamshell Pipe Cutting Tool

The LC (Low Clearance) series is designed to fit into tight working areas as well as minimize machine weight. These clamshells are lightweight, but retain rigidity during operation.

USS Clamshell Pipe Cutting Tool

The USS series combines the low clearance of the LC, while providing additional thickness and strength. The USS clamshells offer heavy-duty construction for even greater rigidity during operation. Larger diameter clamshells must be rigid to maintain a consistent and accurate machining process.

WD Clamshell Pipe cutting Tool

The WD (Worm Drive) Clamshell's gear system provides the necessary power to cut extra heavy wall pipe and operate on pipes greater than 40". Mactech's large diameter clamshells are exceptional OD mount facing tools for heat exchange resurfacing.



CALL **1800 023 859** TO SPEAK WITH ONE OF OUR TECHNICIANS

Innovative Onsite Engineered Solutions

HEAD OFFICE:

Unit 2, 52 Vinnicombe Drive, Canningvale, Perth, WA, Australia. 6155
www.mactechaustralia.com.au • alan@mactechaustralia.com.au

Ph: +61 (08) 9455 6677

Mob/cell: 0409 081 343

Fax: +61 (08) 9455 6644

CLAMSHELL PORTABLE LATHES

MACTECH PORTABLE MACHINING SOLUTIONS

GENERAL INFORMATION

Each Mactech Clamshell comes complete with:

- In-line air, right angle air, or hydraulic drive
- Air Caddy with inline lubricator and filter
- Complete set of Tool Blocks & Slides
- Locator pad set to cover entire range
- All required hand tools
- Gang box for machine storage
- Operating manual with parts list

Special Options:

- Hydraulic Power Supply 5, 10, 15 or 20HP
- Counterbore Attachment Module
- Single Point Module
- Axial Feed Weld Overlay Removal Module

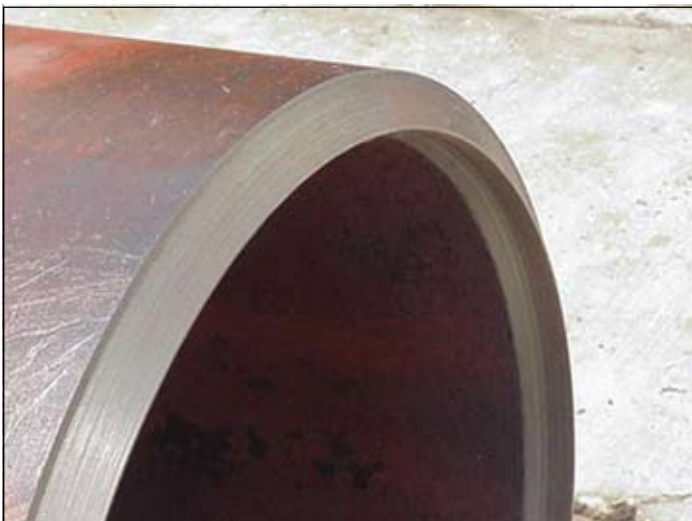
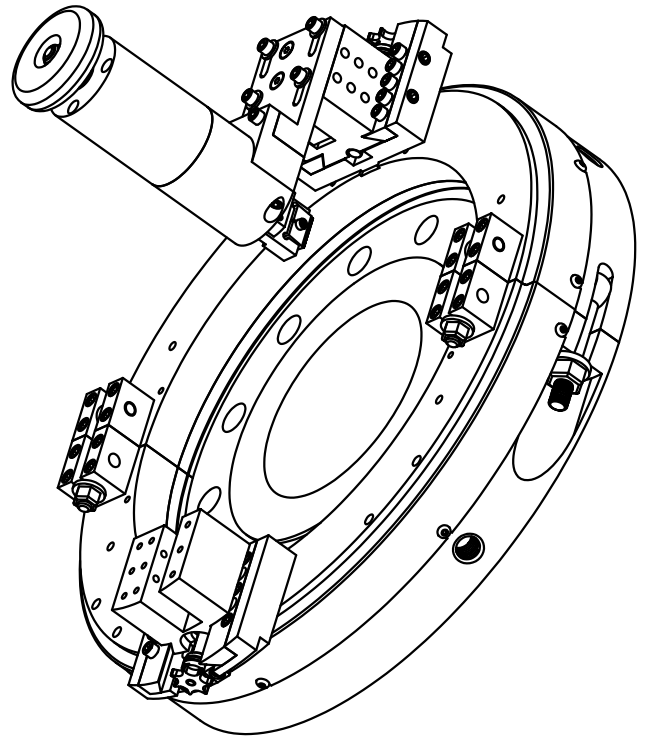

DRIVE OPTIONS

- | | |
|---------------------------------------|---|
| In-Line Air Drive: | 105 RPM, 1.45 HP
Standard for 2-12" Clamshell cutting tools
(Mactech model 802-812) |
| In-Line Air Drive: | 97 RPM, 3.50 HP
Standard for 14-60" Clamshell cutting tools
(Mactech model 814-860) |
| Right Angle and Reverse Drive: | Made available to alleviate clearance issues and come in several variations and size. |
| Hydraulic Drive Motor: | Available for all Clamshell cutting tool sizes |

CLAMSHELL PORTABLE LATHES

MACTECH PORTABLE MACHINING SOLUTIONS

LC CLAMSHELL

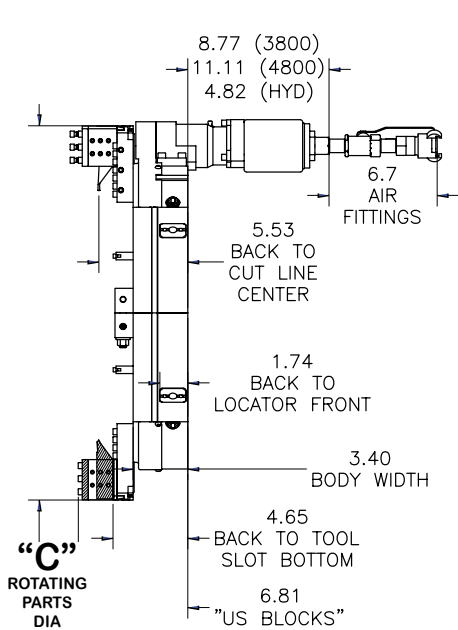
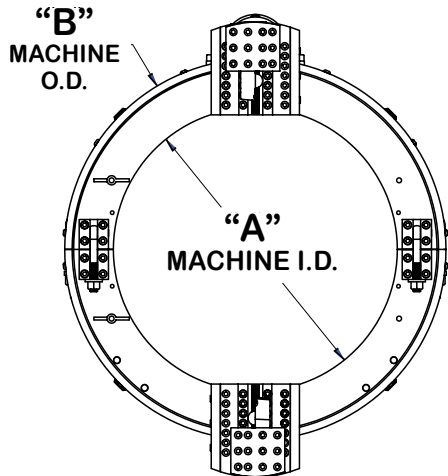

USS CLAMSHELL

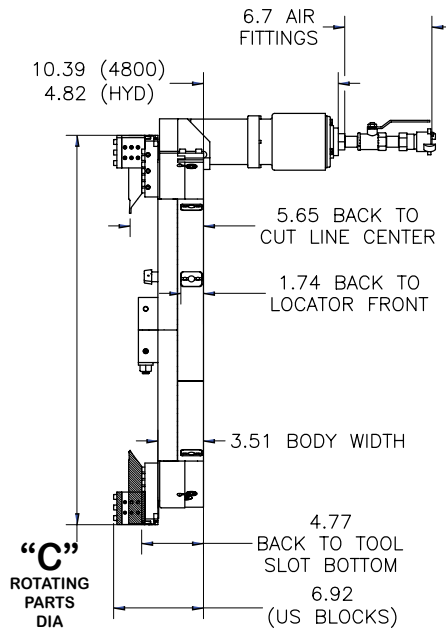
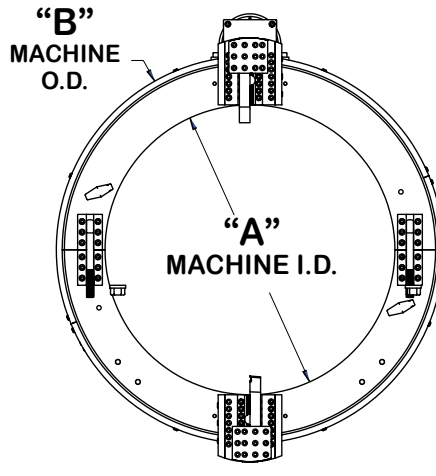

WD CLAMSHELL

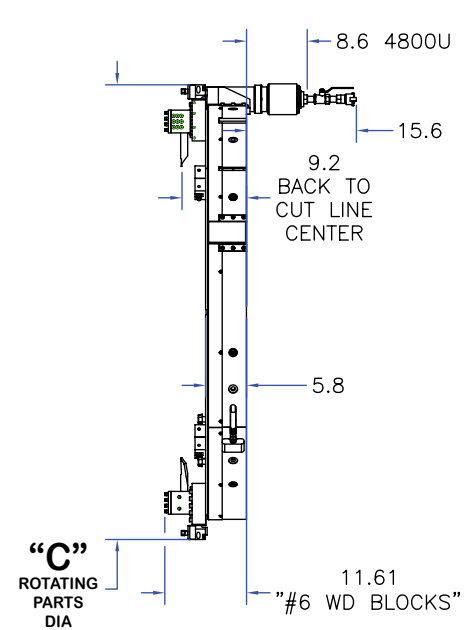
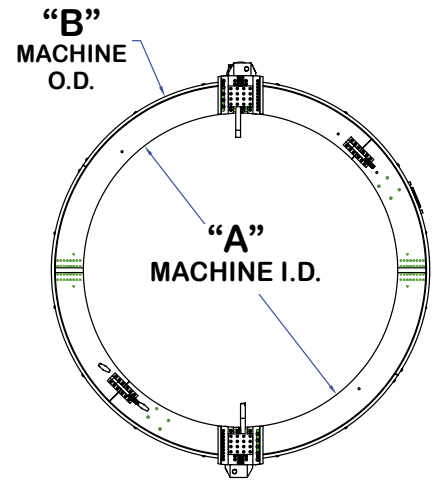

LC CLAMSHELL	Clamshell Model	802LC	804LC	806LC	808LC	810LC	812LC	814LC	816LC
	A - Machine I.D.	2.88	5.00	7.12	9.12	11.25	13.25	14.50	16.50
	B - Machine O.D.	7.10	9.98	12.10	14.10	16.23	18.21	19.48	21.48
C - #2 Slides	11.13	12.75	14.87	16.87	19.00	21.00	22.25	24.25	

USS CLAMSHELL	Clamshell Model	816USS	820USS	824USS	828USS	830USS	832USS	836USS
	A - Machine I.D.	16.50	20.50	24.50	28.50	30.50	33.00	37.00
	B - Machine O.D.	23.40	27.40	31.40	35.40	37.50	40.00	44.00
C - #3 Slides	26.00	30.00	34.00	38.00	40.00	42.50	46.50	

WD CLAMSHELL	Clamshell Model	832WD	836WD	843WD	848WD	860WD
	A - Machine I.D.	33.00	37.00	44.00	49.00	61.00
	B - Machine O.D.	43.00	47.00	54.00	59.00	71.00
C #6 WD Slides	48.61	52.61	59.61	64.61	76.61	

CLAMSHELL PORTABLE LATHES

MACTECH PORTABLE MACHINING SOLUTIONS

SPECIFICATIONS

Frame:

The aluminum frame is a split ring assembly capable of being disassembled to be installed around in-line piping. The frame has bearing mountings for the rotating head, a drive motor mount, locator pads for mounting to the pipe, and a gear cover.

Cutting Head Assembly:

The cutting head assembly is a heat treated 4140 alloy steel split ring gear assembly, which aligns with the split lines of the frame enabling the machine to be split in half. The cutting head has an integral spur gear on the outside diameter, and mounting devices for tool holders.

Drive Assembly:

The drive motor assembly mounts to the frame and is arranged with a pinion gear on a shaft. The drive motor mount bracket is designed to accept the reaction torque generated by the drive motor.

Bearings:

The cutting head runs on precision bearings that provide for both axial and radial force reactions experienced in pipe machining. Mactech utilizes two separate radial bearing arrangements in every machine, providing maximum rigidity of operation. They are designed so that adjustments are not required.

Tool Holders (Blocks):

The tool holders mounted to the cutting head assembly are provided with automatic radial feed "star wheel" mechanisms. They are designed to maintain the radial clearance equal to the frame diameter and feature adjustable gibs for tool support.

Locator Pads:

Adjustable locator pads are actuated by jackscrews from the outside of the frame. A set of locator pads with extensions to cover the machine's operating range is provided with each machine. Additional sizes for each machine are available.

Tool Bits:

Mactech tool bits are available for severing, severing and double beveling, severing and beveling on the side of the cut on which the clamshell is mounted (right hand), severing and beveling on the opposite side of the cut (left hand), counterboring, socket weld removal, etc.



CALL 1800 023 859 TO SPEAK WITH ONE OF OUR TECHNICIANS

Innovative Onsite Engineered Solutions

HEAD OFFICE:

Unit 2, 52 Vinnicombe Drive, Canningvale, Perth, WA, Australia. 6155
www.mactechaustralia.com.au • alan@mactechaustralia.com.au

Ph: +61 (08) 9455 6677

Mob/cell: 0409 081 343

Fax: +61 (08) 9455 6644