

832USS CLAMSHELL LATHE

MACTECH PORTABLE MACHINING SOLUTIONS

Features

- Sever or simultaneous Sever/Bevel 26 to 32 inch diameter pipe.
- Cold cutting in hazardous environments.
- Exceptionally rigid, split-frame for precise on-site machining.
- Lightweight, low clearance design for easy handling in tight working spaces.
- Tool Holder accepts standard 3/4 or 1 inch tool bits.
- Air Caddy (air filter and oiler) included with air drive systems.
- Custom setups and drives available for your application.

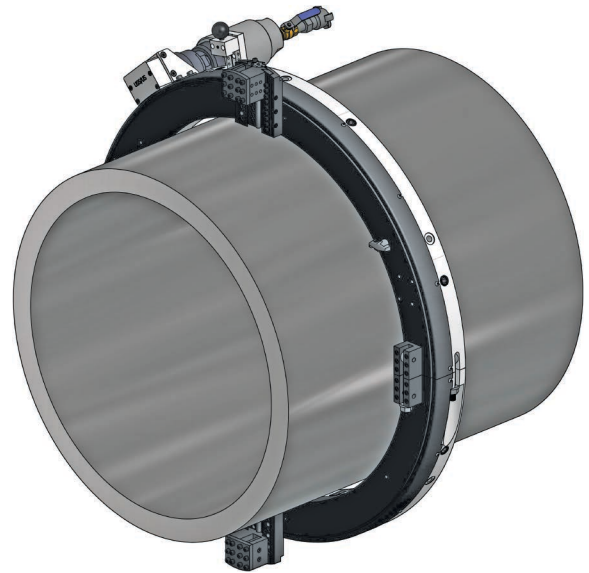

Mactech 832USS Clamshell Lathe

Application Range

26 to 32 inch (660 to 813 mm) diameter pipe

Feed

Feed Mechanism: 7 point starwheel and tripper
Feed Rate: .0035 inch (0.09 mm) per revolution

Drives

Air Drive

Air supply requirement: 100 cfm @ 100 psi
(2.8 m³/min @ 6.9 bar)

Hydraulic Drive

HPU requirement: 10-15 gpm @ 1000 psi
(38-57 lpm @ 69 bar) continuous pressure
Hydraulic motor includes hose whips and quick-disconnects

Weights (includes tool blocks and motor)

Operating Weights

832USS Air Drive: 272 lbs. (123 kg)

832USS Hydraulic Drive: 273 lbs. (124 kg)

Shipping Weights

832USS Air Drive: 455 lbs. (206 kg)

832USS Hydraulic Drive: 443 lbs. (201 kg)

Options

- Full line of tool bits
- Right angle and reversible drives
- Single Point machining attachment
- Axial Feed machining attachment
- Counterbore/Facing attachment
- Hydraulic Power Unit

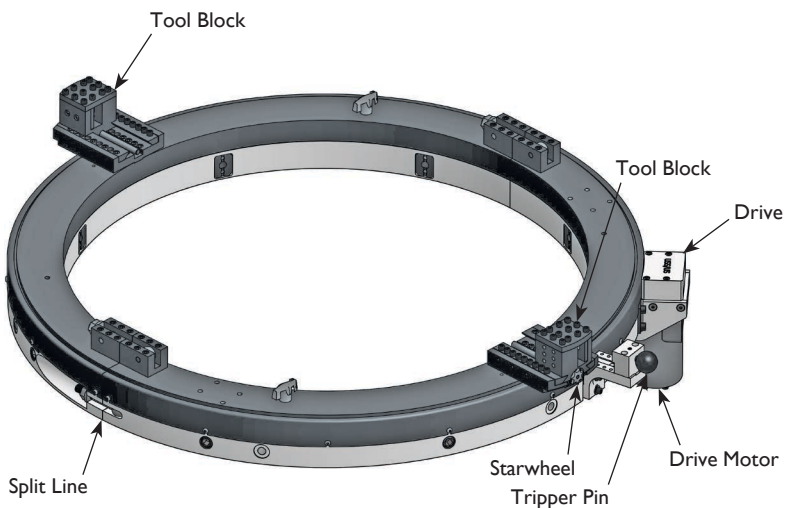

832USS Clamshell Lathe Components



MACTECH AUSTRALIA HEAD OFFICE:

Unit 2, 52 Vinnicombe Drive, Canningvale, Perth, WA, Australia. 6155
www.mactechaustralia.com.au • alan@mactechaustralia.com.au

Ph: +61 (08) 9455 6677

Mob/cell: 0409 081 343

Fax: +61 (08) 9455 6644

832USS CLAMSHELL LATHE

MACTECH PORTABLE MACHINING SOLUTIONS

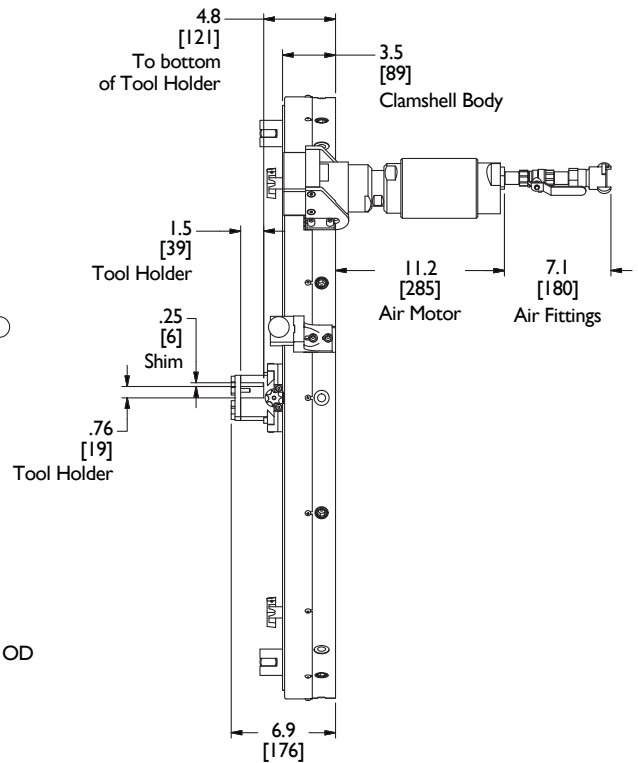
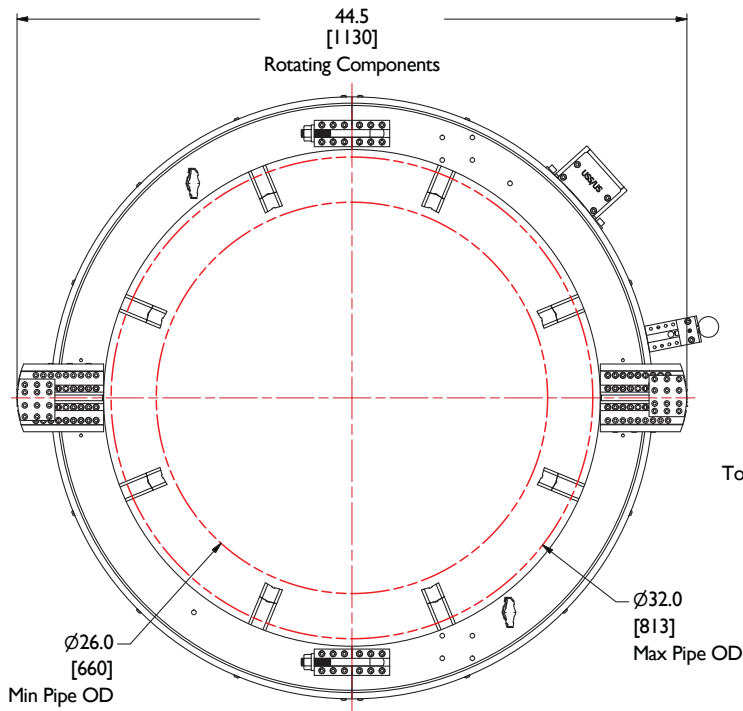

832USS with Air Drive

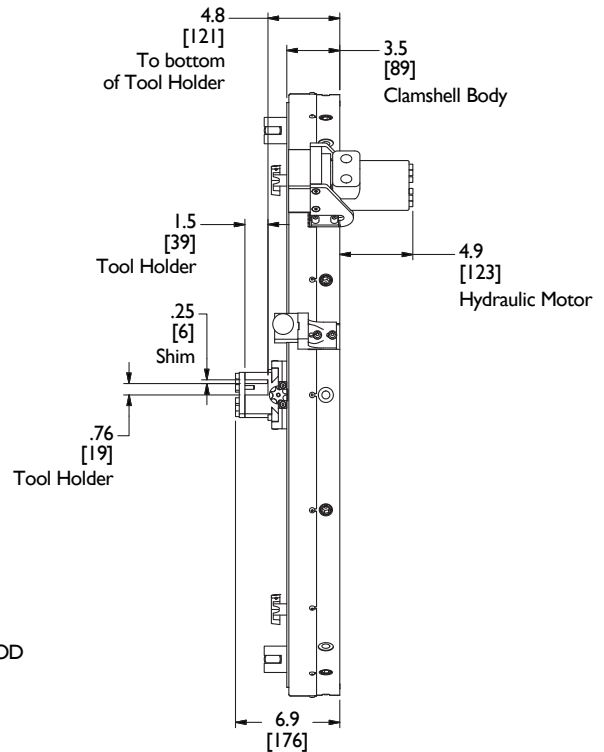
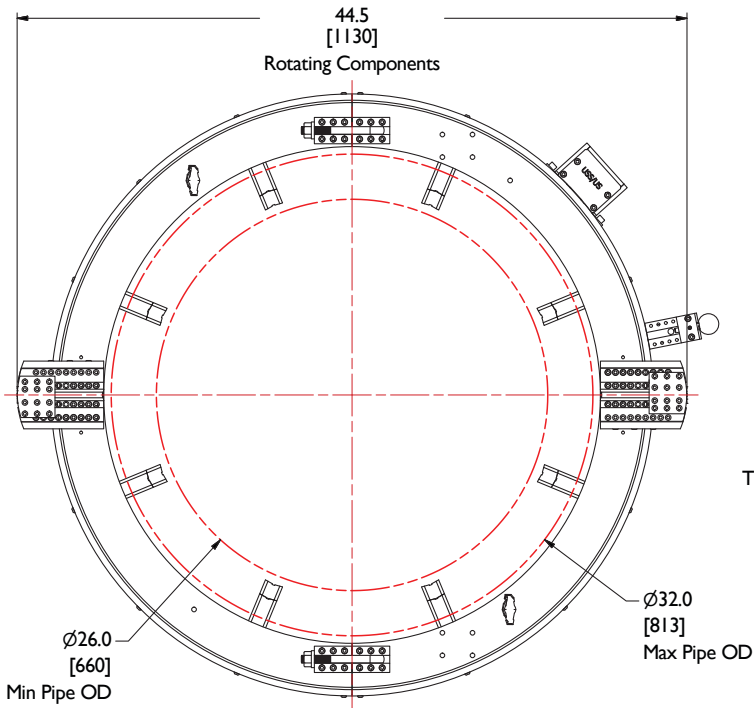

832USS with Hydraulic Drive



MACTECH AUSTRALIA HEAD OFFICE:

Unit 2, 52 Vinnicombe Drive, Canningvale, Perth, WA, Australia. 6155
www.mactechaustralia.com.au • alan@mactechaustralia.com.au

Ph: +61 (08) 9455 6677

Mob/cell: 0409 081 343
Fax: +61 (08) 9455 6644