

"Prepzilla" MILLHOG®

I.D. Clamping End Prep Tool
1.575 I.D. to 8.625 O.D.
40 mm I.D. to 219.1 mm O.D.

The world standard for all other tools of its type on the market, this tool is powerful, smooth and quiet running.

Key Features

- Only (8) sets of clamps to cover entire range
- One mandrel covers entire range
- Single point attachment allows preps on all wall thicknesses at any angle
- Optional cross feed for flange facing, pipe grooving and severing
- EscoLock blade locking system for maximum blade life
- Dual opposed tapered roller bearings deliver rock solid performance
- Heavy duty clamping system does not break
- Directional exhaust
- Low R.P.M. with tremendous torque
- Produces thick chips on all highly alloyed tube and pipe, without cutting fluids

Typical applications include;

End prepping stainless steel, super duplex, P-91 and other hard to machine alloys.

Cross Feed Attachment

This optional attachment easily bolts to the Prepzilla and is easy to use. It permits flange facing, grooving for couplings, and torched end severing.

High Performance, Low Maintenance

Like all other MILLHOGS, high performance and low maintenance were important design criteria for the Prepzilla MILLHOG®. This tool is suitable for prepping any type of tube material including super duplex and uses one mandrel to cover the full operating range of the tool.

Prepzilla Clamp Rib Selector and corresponding spares

Clamp Set	I.D. Range				Mandrel Part #	Draw Rod Size	Actuator		Retention Spring
	in	mm	Part #	Roll Pin					
P-01	1.575	2.050	40.0	52.1	P-30	1.575	P-11	P-14 P-10	P-10A
P-02	2.025	2.505	51.4	63.6	P-30	1.575	P-11	P-14 P-10	P-10A
P-03	2.475	2.955	62.9	75.1	P-30	1.575	P-11	P-14 P-10	P-10A
P-04	2.925	3.405	74.3	86.5	P-30	1.575	P-11	P-14 P-10	P-10A
P-02 & P-05	3.375	3.855	85.7	97.9	P-30	1.575	P-11	P-14 P-10	P-10A
P-03 & P-05	3.825	4.305	97.2	109.3	P-30	1.575	P-11	P-14 P-10	P-10A
P-04 & P-05	4.275	4.755	108.6	120.8	P-30	1.575	P-11	P-14 P-10	P-10A
P-02 & P-06	4.725	5.205	120.0	132.2	P-30	1.575	P-11	P-14 P-10	P-10A
P-03 & P-06	5.175	5.655	131.4	143.6	P-30	1.575	P-11	P-14 P-10	P-10A
P-04 & P-06	5.625	6.105	142.9	155.1	P-30	1.575	P-11	P-14 P-10	P-10A
P-02 & P-07	6.075	6.555	154.3	166.5	P-30	1.575	P-11	P-14 P-10	P-10A
P-03 & P-07	6.525	6.980	165.7	177.3	P-30	1.575	P-11	P-14 P-10	P-10A
P-04 & P-07	6.950	7.430	176.5	188.7	P-30	1.575	P-11	P-14 P-10	P-10A
P-02 & P-08	7.400	7.880	188.0	200.2	P-30	1.575	P-11	P-14 P-10	P-10A
P-03 & P-08	7.850	8.330	199.4	211.6	P-30	1.575	P-11	P-14 P-10	P-10A
P-04 & P-08	8.300	8.780	210.8	223.0	P-30	1.575	P-11	P-14 P-10	P-10A

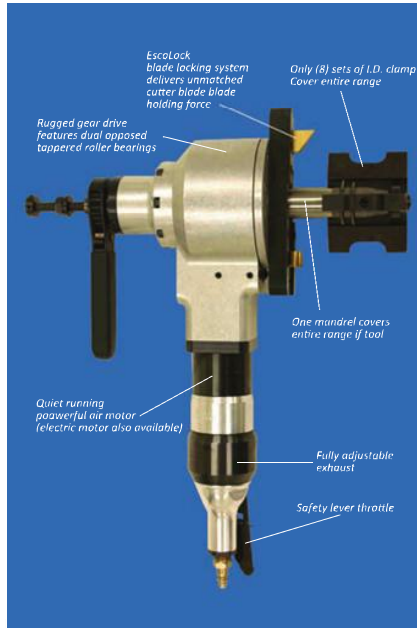

Prepzilla Standard Kit Includes:

Gear Head, Feed Mechanism, 2 HP Pneumatic Motor (electric may be substituted), 8.625in Tool Post, Draw Rod Assembly, 1.575in Mandrel, Hose with couplings, dirt stopper and oiler, & Carrying Case. (deluxe kit shown that includes all clamp ribs and pads for entire range).



The Prepzilla MILLHOG® cuts heavy wall pipe and tube, producing a heavy chip with no cutting oils; resulting in perfect end preps.

Only (8) sets of clamps and one mandrel cover the entire range.



The available electric motor is easily swapped with the pneumatic motor when air is not available. It produces awesome power and the variable speed motor is ideal for all types of tube and pipe alloy. Like the pneumatic drive, cutting oil is not required.

Specifications

Prepzilla MILLHOG®	
Working Range:	1.575" (40 mm) I.D. to 8-5/8" (219.1 mm) O.D.
Motor, pneumatic	2 h.p. (1.492 kw)
Air Pressure	90 psi (6.2 bar)
Air Volume	80 cfm (2690 lt/min.)
Speed	30 RPM
Motor, electric	110 volt 1800 watt 40/60 hz, 230 volt (consult factory)
Minimum Clearance	8-3/4" (222.3 mm)
Head Length	19-3/4" (501.7 mm)
Working Weight	40 lbs. (18.2 kg)
Shipping Weight	110 lbs. (50 kg)
Shipping Dimensions	27" x 21" x 7" (686 mm x 534 mm x 178 mm)
*Manufacturer reserves the right to change specifications without notice.	



MACTECH AUSTRALIA HEAD OFFICE:

Unit 2, 52 Vinnicombe Drive, Canningvale, Perth, WA, Australia. 6155
www.mactechaustralia.com.au • alan@mactechaustralia.com.au

Ph: +61 (08) 9455 6677

Mob/cell: 0409 081 343

Fax: +61 (08) 9455 6644